



NOR-LAKE, INCORPORATED
727 Second Street
Hudson, Wisconsin 54016

800-955-5253
715-386-2323
866-961-5253 Parts
800-388-5253 Service
715-386-6149 FAX
www.norlake.com

LOW GLASS DIPPING/DISPLAY MERCHANDISERS



PROJECT:

ITEM NUMBER:

MODEL NUMBER:

SPECIFICATIONS FOR: HF040-WWG/OL, HF100-WWG/OL, HF160-WWG/OL, HF230-WWG/OL

- **Finish:** 24 gauge white painted galvanized steel interior and exterior
- **Insulation:** 3" thick walls and 2-1/2" floor with foamed-in-place "zero ODP" urethane insulation
- **Hardware:** Frameless double pane tempered glass viewing window, with NSF51 approved powder coated top and bottom aluminum extruded trims, provides enhanced structural stability and appearance. Stainless steel top and attached superstructure. Stainless steel serving deck. Heavy-duty epoxy-coated wire can support racks. Transparent acrylic dipping compartment lids (hinged with full length handle). Tempered glass ends improve product visibility. Standard electronic controller increases reliability and saves energy by maintaining consistent product temperature. Condenser filter screen, removable without tools, for easy condenser coil cleaning (HF160-WWG/OL and HF230-WWG/OL models). Screen should be cleaned every three months depending on operating environment.
- **Electrical:** 115 volt, 60 HZ, 1 phase with cord and plug
- **Refrigeration:** Eco-friendly R290 refrigerant. Cold wall evaporator. Low maintenance condenser coil. Temperature range: 5°F to -5°F (-15°C to -21°C)
- **Approvals:** UL and CUL Safety and UL Sanitation Listed.**

STANDARD FEATURES

- Rounded rear stainless steel heated top improves operator comfort
- Lower back rail provides improved operator ergonomics
- Energy efficient, long lasting LED lighting
- Rear air intake with side and rear discharge eliminates front grille and allows full front of cabinet for graphics
- Side compartment grille improves the air circulation and accessibility during servicing
- Independent on/off light switch
- Drain with hose connection

- Equipped with levelling legs to correct unlevel flooring situations
- Warranties: 2 year parts and labor, 5 year compressor

OPTIONS

- Custom colors
- Removable can holders with white overnight can covers
- Dipper well
- Removable frost shields
- Leg kit
- Casters
- Lid locking kit (less locks, requires one kit per lid)

*Most options are available one week from receipt of order. Please contact us for specific questions.

**C-UL is Underwriters Laboratories Safety Certification Mark which indicates that UL has tested the equipment to applicable CSA Standards.

**UL Sanitation is Underwriters Laboratories Sanitation Mark which indicates that UL has tested the equipment to applicable NSF Standards.

Model	HF040-WWG/OL	HF100-WWG/OL	HF160-WWG/OL	HF230-WWG/OL
Crated Height	60"	60"	60"	60"
Crated Width	45"	57"	80-1/2"	104"
Crated Depth	40"	40"	40"	40"
Crated Weight (lbs.)	264	407	545	660
Interior Display Height	20"	20"	20"	20"
Interior Storage Height	*	12-1/2"	12-1/2"	12-1/2"
Interior Display Width	21"	42"	63"	84"
Interior Storage Width	*	21"	42"	63"
Interior Depth	21-1/2"	21-1/2"	21-1/2"	21-1/2"
Can Capacity display **	4	8	12	16
Can Capacity storage **	0	4	8	12
Overall Height	50"	50"	50"	50"
Overall Width	27-1/4"	48-1/4"	69-1/4"	90-1/4"
Overall Depth	27-1/2"	27-1/2"	27-1/2"	27-1/2"
Number of Legs or Casters (optional)	4	4	4	4
Condensing Unit Size	3/5	3/5	5/6	5/6
Refrigerant	R290	R290	R290	R290
Electrical Characteristics	115/60/1	115/60/1	115/60/1	115/60/1
Cord and Plug Furnished	Yes	Yes	Yes	Yes
Maximum Fuse Size	15	15	15	15
Nema Plug Configuration	5-15P	5-15P	5-15P	5-15P
Total Amp Draw	5.9	5.9	7.2	7.2

* Storage compartment not available on this model. ** Capacities in 9-1/2" diameter, 3 gallon cans.

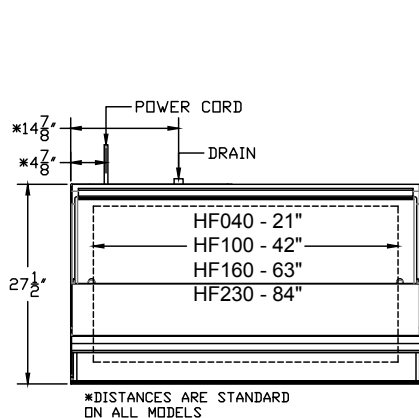

TOP

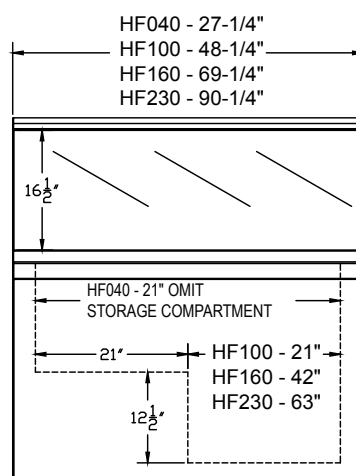

FRONT

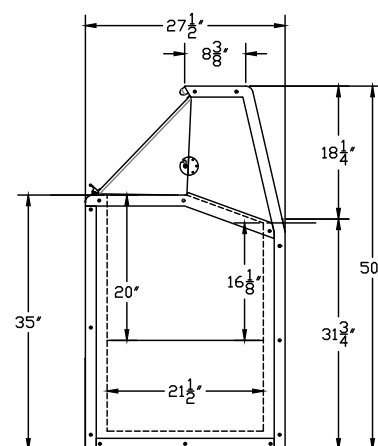

SIDE



Revision Date: 4/20
Part Number: 162291